

CPU

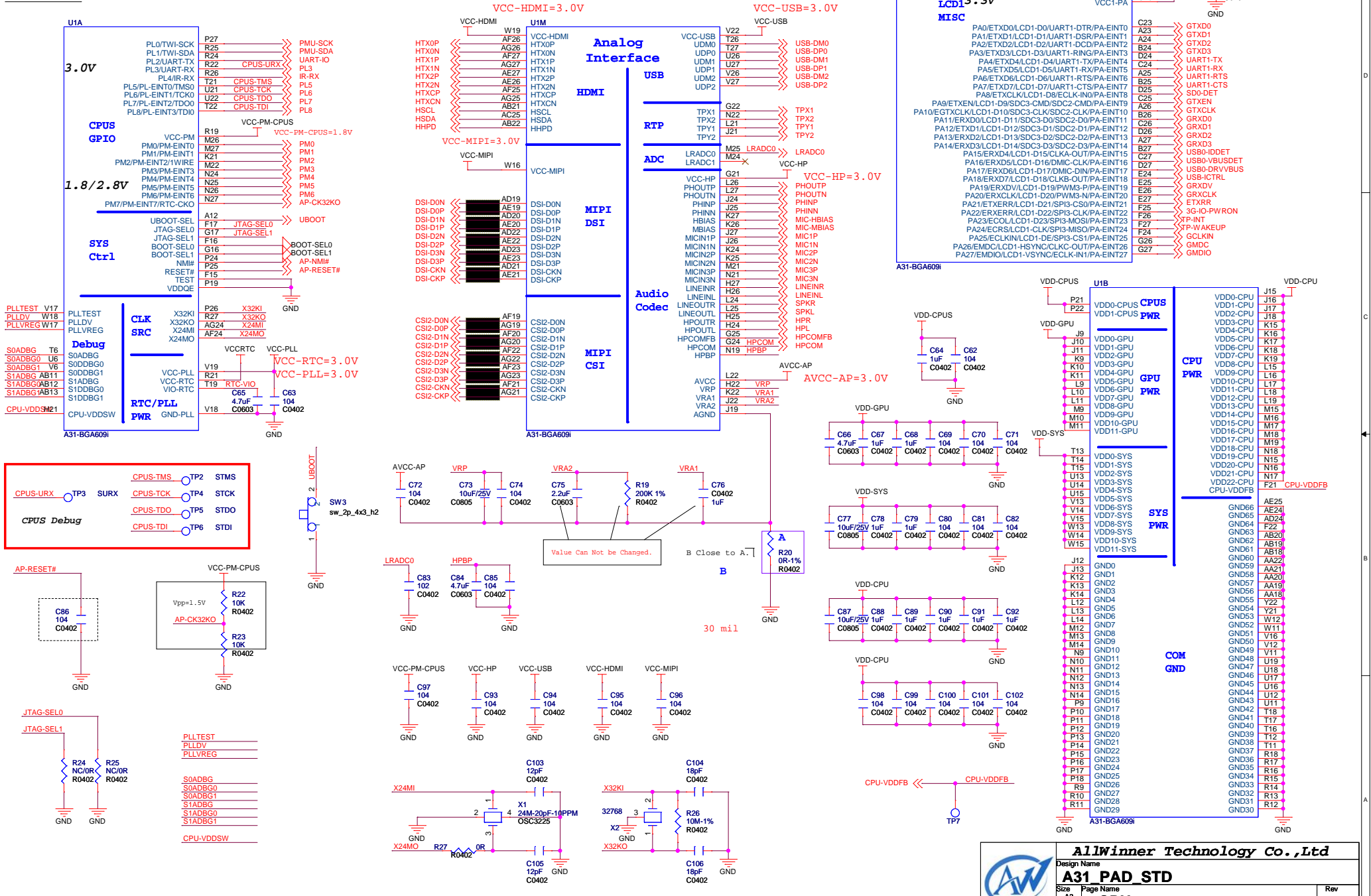

DDR3

1.5/1.35/1.2V
DDR3/LVDDR3/LPDDR2

Please copy DRAM PCB template and follow PCB layout guide. The circuit is only for single-side PCB layout.

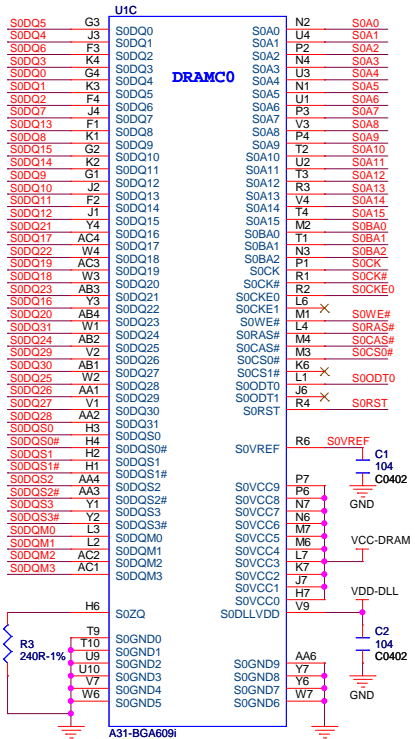

VCC-DRAM=1.5V
VDD-DLL = 1.1V

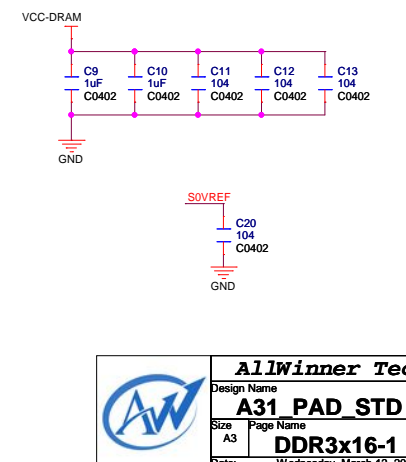
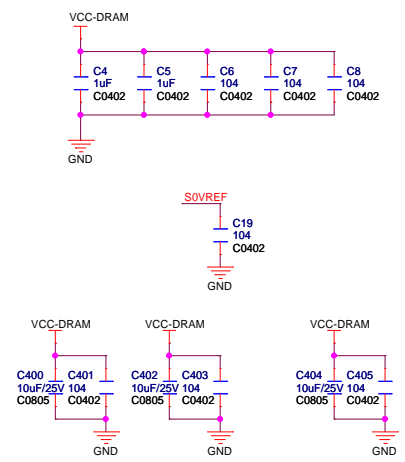
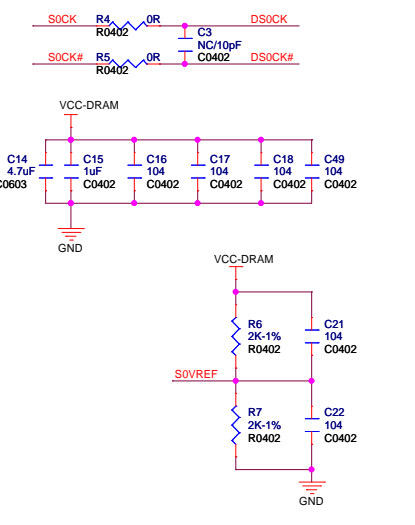
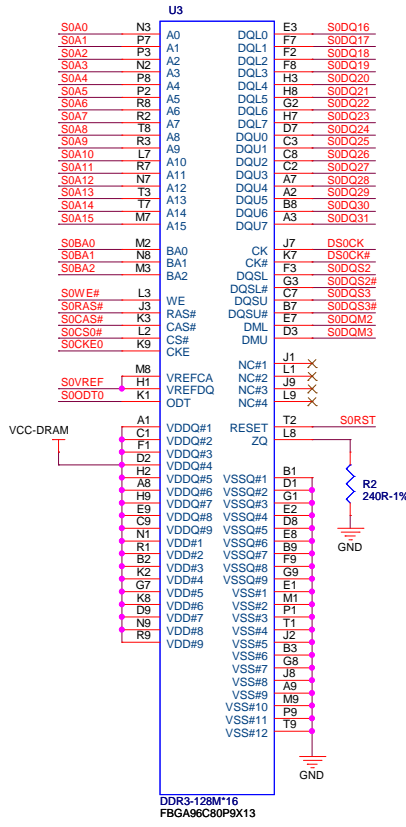
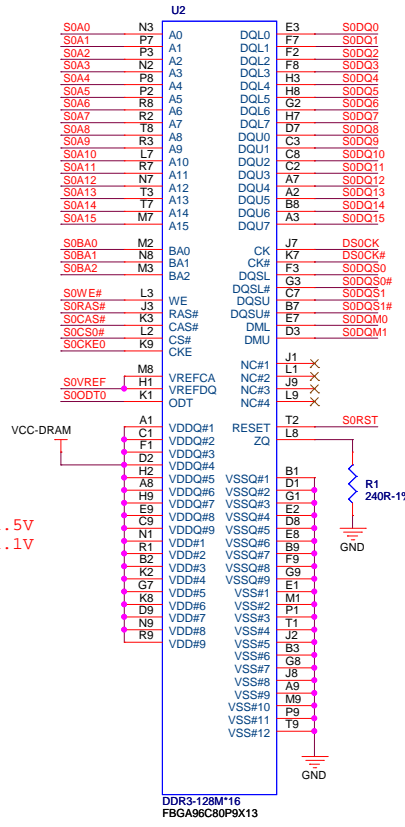

		AllWinner Technology Co., Ltd	
		Design Name A31 PAD STD	
Size A3	Page Name DDR3x16-1	Date: Wednesday, March 12, 2014	Sheet 2 of 18

NAND

Nand Flash, eMMC-NAND, etc

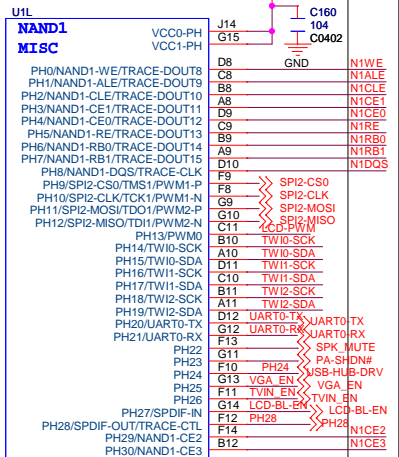
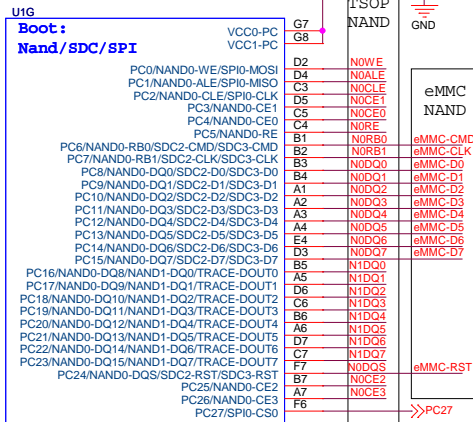

TWI0 pull-up by VCC-PE in Camera Page

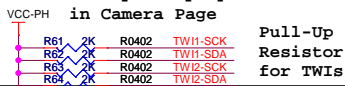

Both eMMC NAND and TSOP NAND layout together

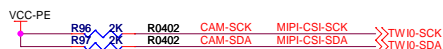
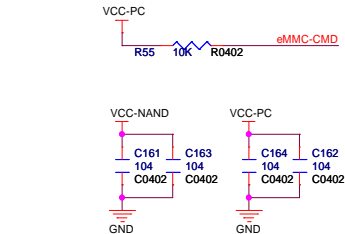
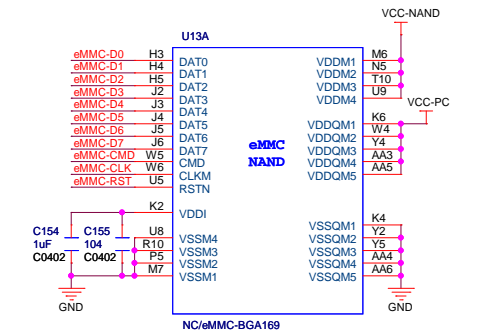

VCC-NAND = 3.0V
VDD1-LPDDR2 = 1.8V

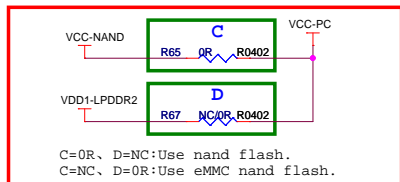

C=0R, D=NC:Use nand flash.
C=NC, D=0R:Use eMMC nand flash.

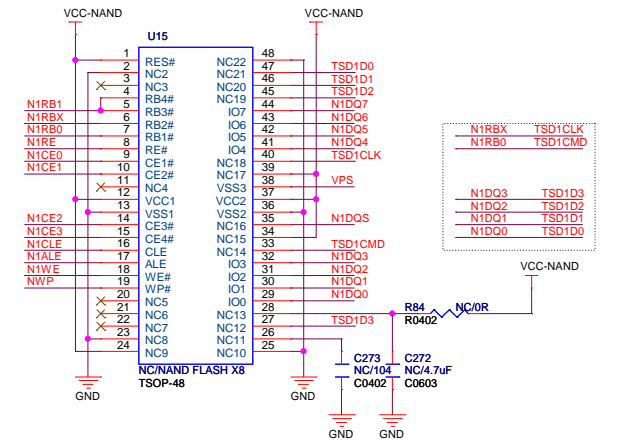
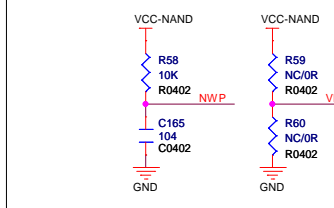
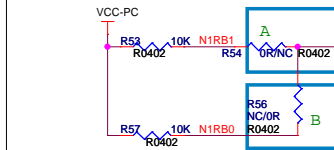
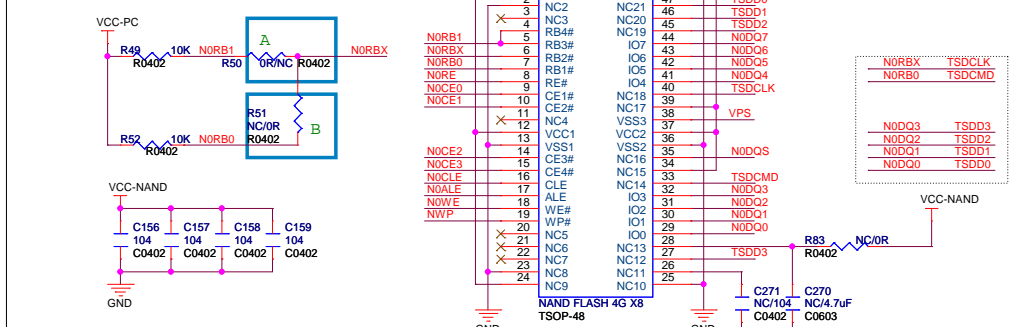

TSSOP CE Count(1)	Resistor A	Resistor B
1	Disconnect	Disconnect
2	Connect	Disconnect
4	Disconnect	Connect

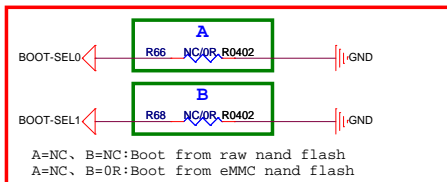

A=NC, B=NC:Boot from raw nand flash
A=NC, B=0R:Boot from eMMC nand flash

Design Name: A31 PAD STD
Size: A3
Date: Monday, March 10, 2014
Sheet: 4 of 18

POWER/PMU

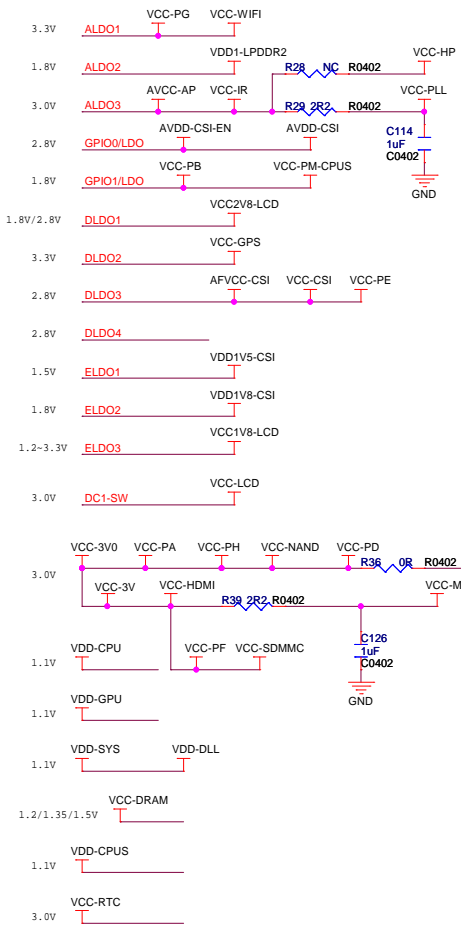

NOTE:
Q1 vth < 1.5V & R < 30mohm @ vgs = 4.5V

P-MOSFET option:
1. TCS1905
2. KD1221
3. ACE5801
4. WPM1481

LDO option:
1. uP0107
2. APL5315
3. GL0125

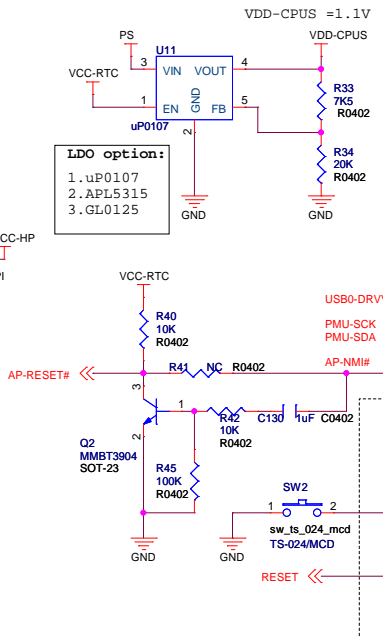

Name	Default Voltage	Maximum Current	Comment	Name	Default Voltage	Maximum Current	Comment
DCDC1	3.0V	1A	For GPIO Default ON	DLDO1	0V	400mA	Default OFF
DCDC2	1.1V	2A	For GPU Default ON	DLDO2	0V	200mA	Default OFF
DCDC3	1.1V	2A	For CPU Default ON	DLDO3	0V	200mA	Default OFF
DCDC4	1.1V	600mA	For System Default ON	DLDO4	0V	100mA	Default OFF
DCDC5	1.2V	2A	For DRAM Default ON	ELDO1	0V	400mA	Default OFF
ALDO1	0V	300mA	Default OFF	ELDO2	0V	200mA	Default OFF
ALDO2	1.8V	300mA	For 1.8V IO/LPDDR2 Default ON	ELDO3	0V	200mA	Default OFF
ALDO3	3V	200mA	For SOC Analog Default ON	DC5LDO	1.1V	200mA	For CPUS, From DC/DC5 Default ON
GPIO0	0V	100mA	Default OFF	DC1SW	3.0V	0.1ohm	For LCD, From DC/DC1 Default OFF
GPIO1	0V	100mA	Default OFF	RTC-VCC	3V	30mA	For RTC Always On

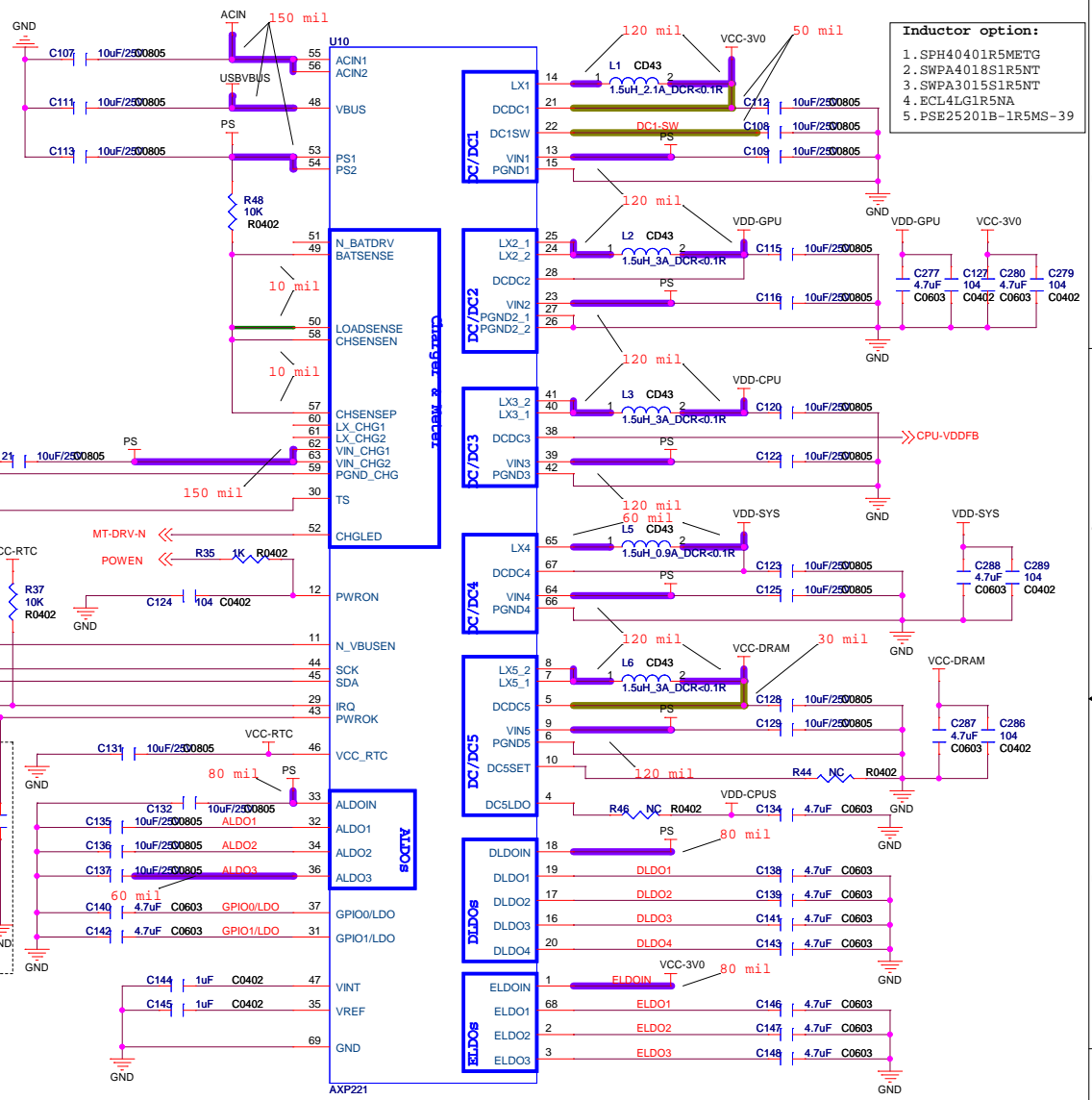

Inductor option:
1. SPH40401R5METG
2. SWPA4018S1R5NT
3. SWPA3015S1R5NT
4. ECL4L61R5NA
5. PSE25201B-1R5MS-39

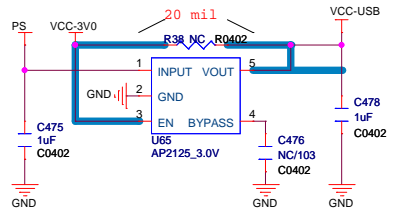

Allwinner Technology Co., Ltd
Design Name: A31 PAD STD
Page Name: PMU
 Date: Wednesday, March 12, 2014 Sheet 5 of 18

POWER-DC/DC

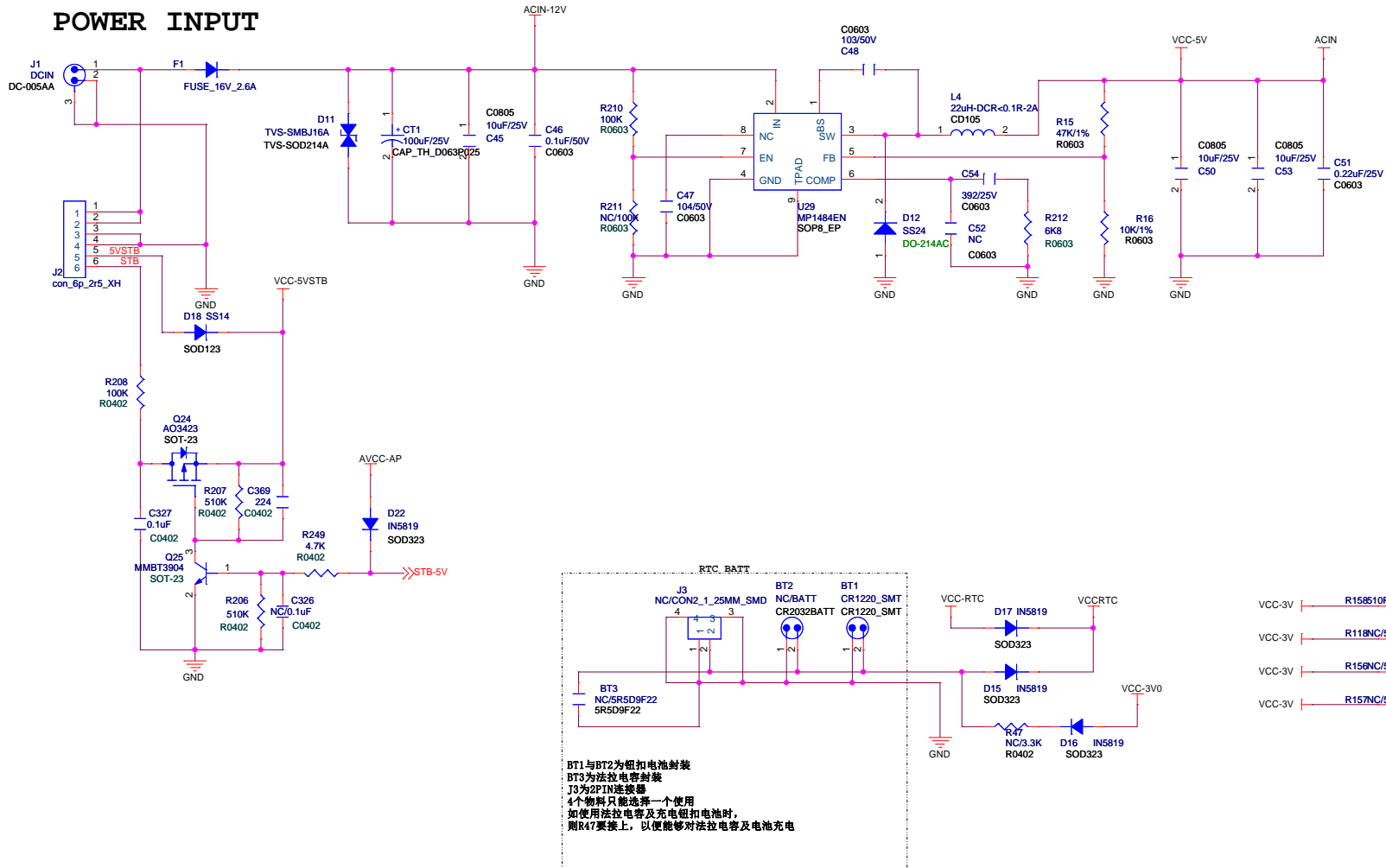

BT1与BT2为纽扣电池封装
 BT3为法拉电容封装
 J3为2P1W连接器
 4个物料只能选择一个使用
 如使用法拉电容及充电纽扣电池时，
 则R47要接上，以便能够对法拉电容及电池充电

LCD-TP

VCC-PD=3.0V

3.3V LCD

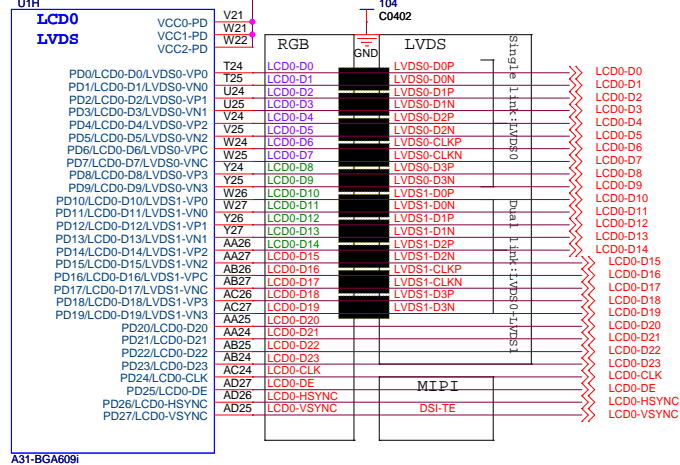

2.8V CSI

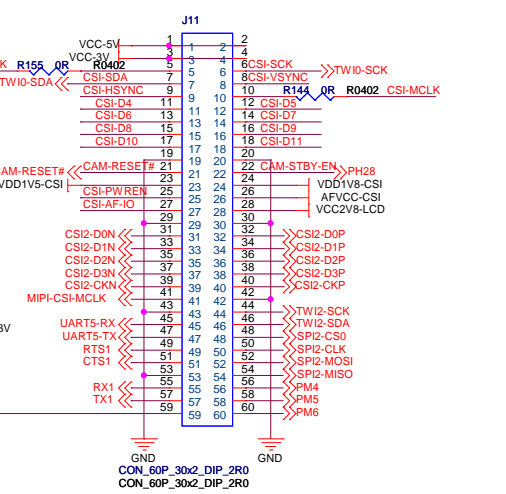
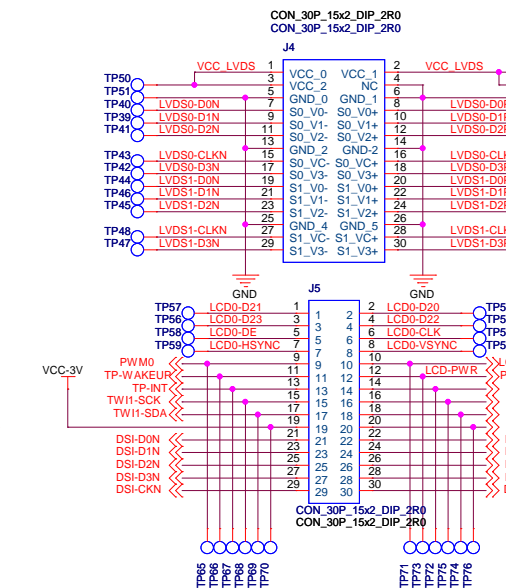
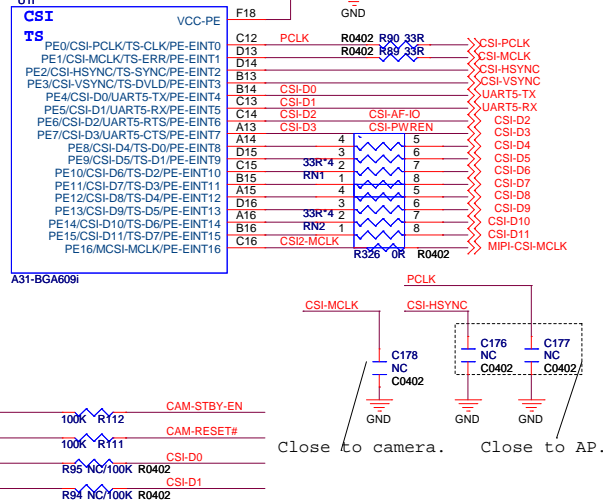

VCC-CSI = 2.8V
 AVDD-CSI = 2.8V
 AFVCC-CSI = 2.8V
 VDD1V8-CSI = 1.5V
 VCC-CSI = 2.8V
 VDD1V8-CSI = 1.8V

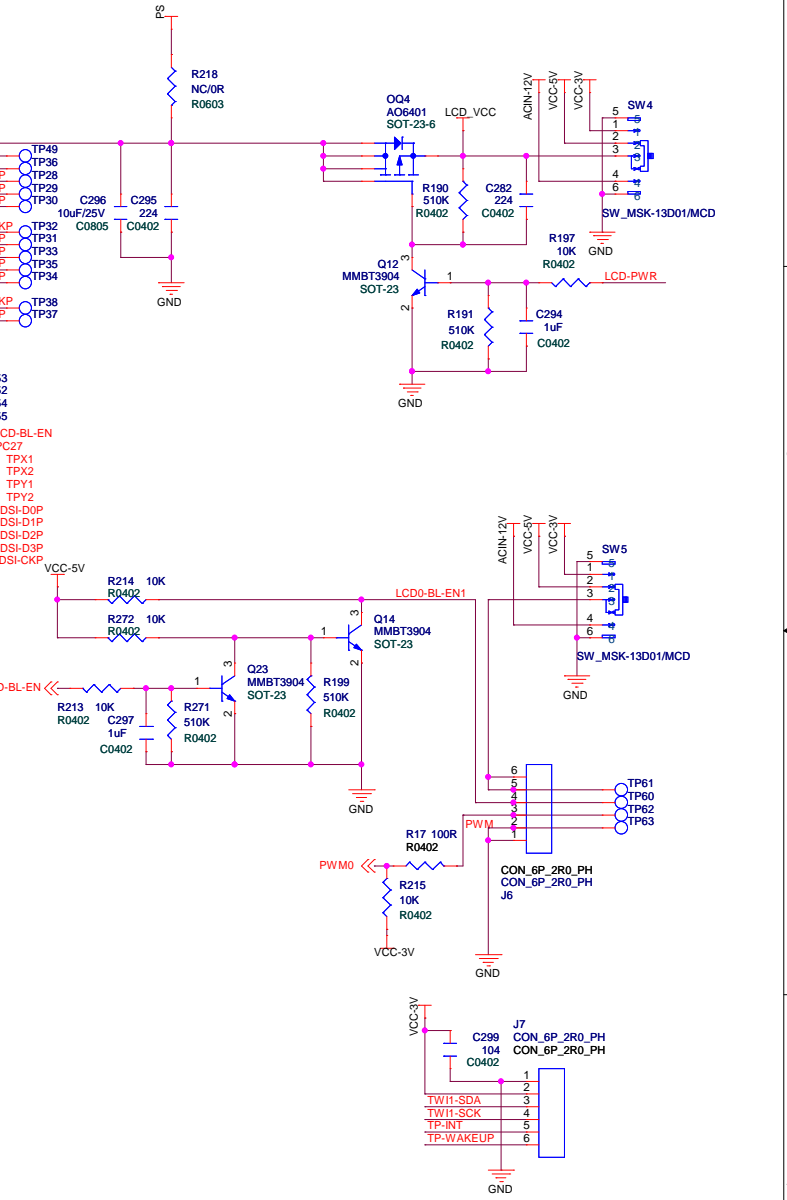

AllWinner Technology Co., Ltd

Design Name: **A31_PAD_STD**

Size: A3 | Page Name: DISPLAY-CAM | Rev: 1.0

Date: Thursday, March 13, 2014 | Sheet: 7 of 18

USB-HUB-OTG&HOST

Differential pairs
Z0= 90 ohm

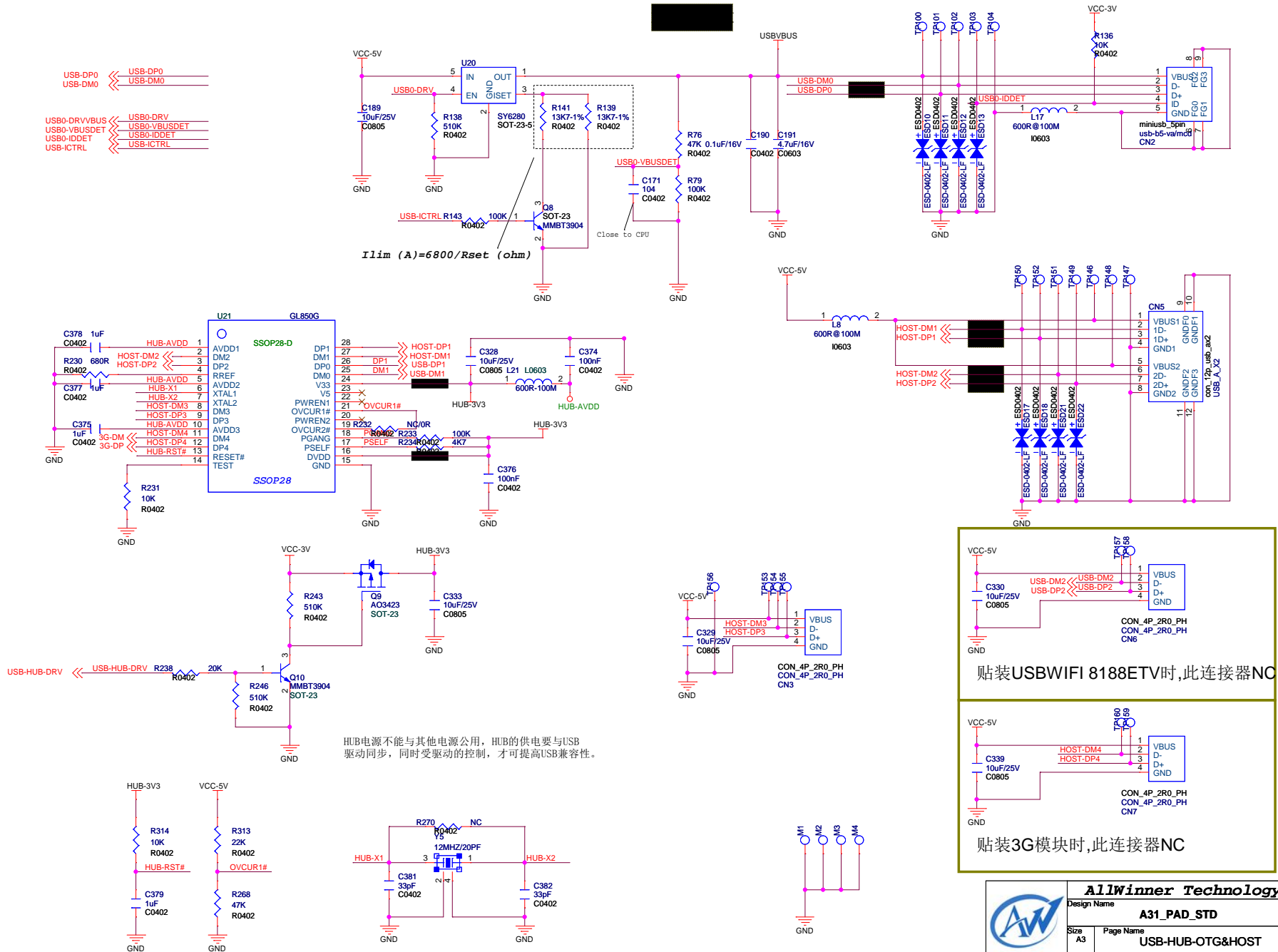

Head Phone & Speaker

Microphone

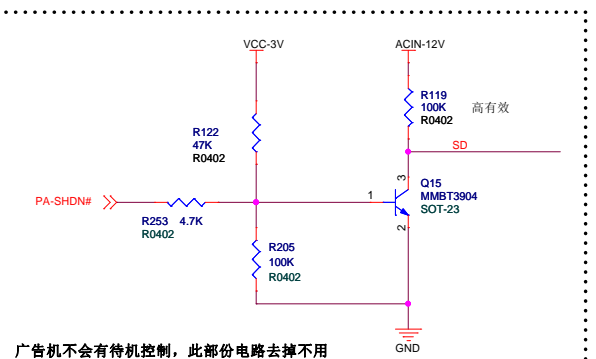
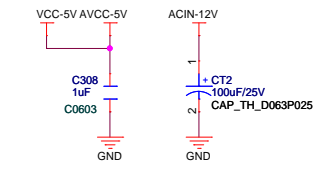
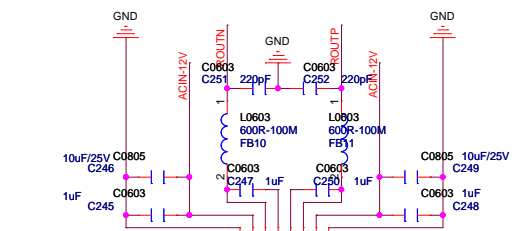
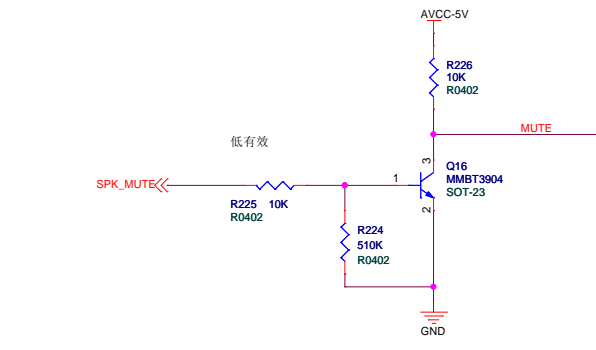
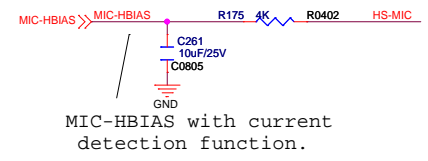
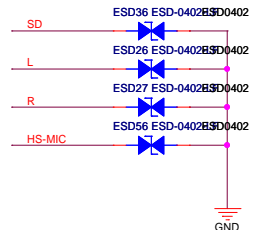
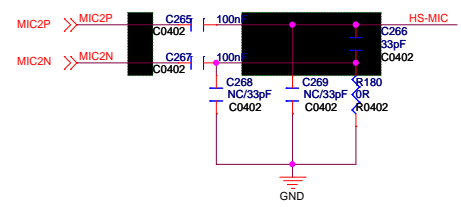
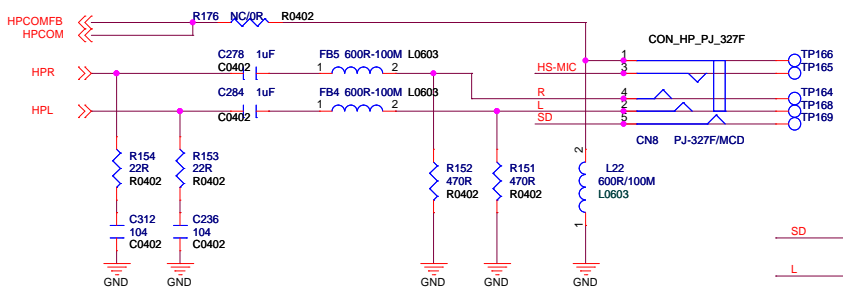

广告机不会有待机控制，此部份电路去掉不用

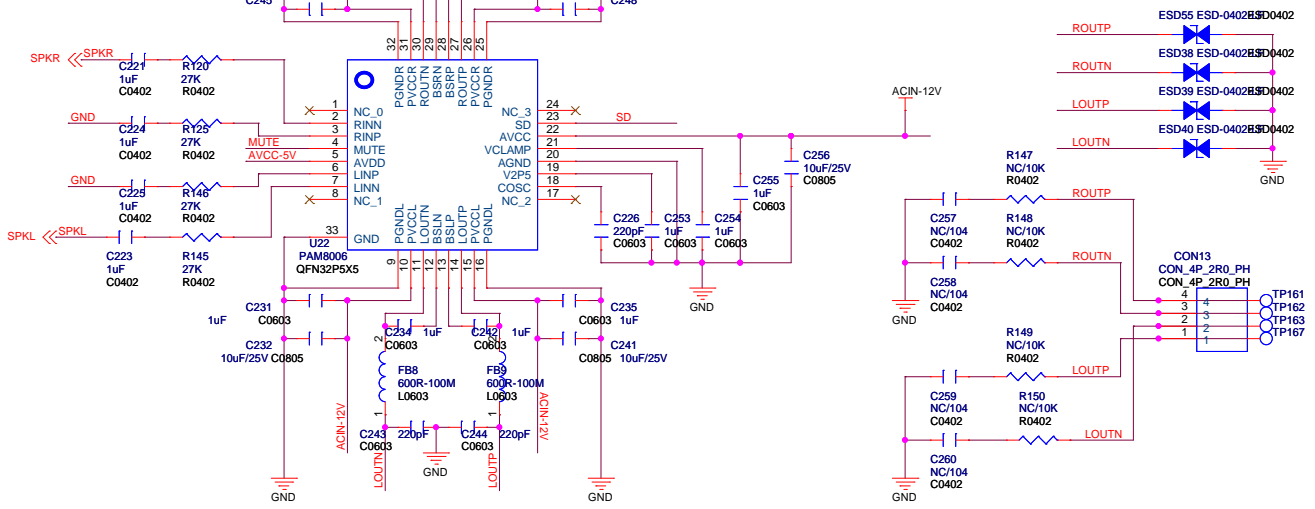

HDMI/SD/TF

HDMI

HDMI

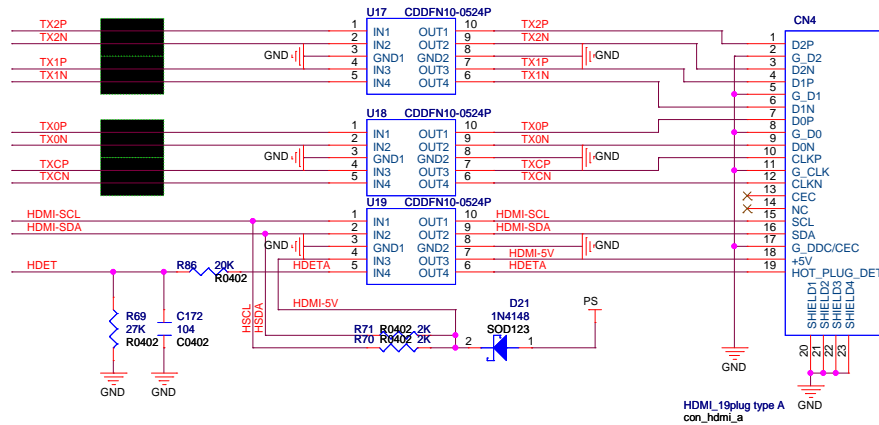
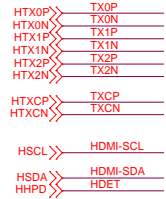

Differential pairs
Z0= 100 ohm

LAYOUT差分走线过孔不能超过2个，有完整铺地。

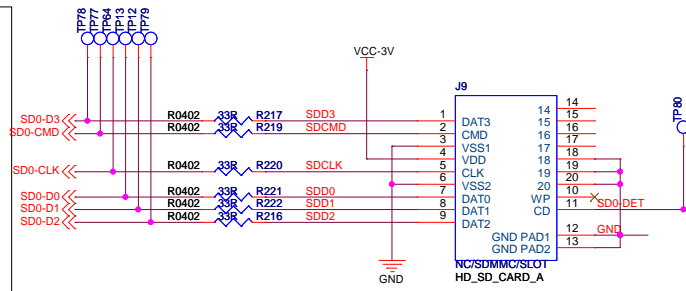
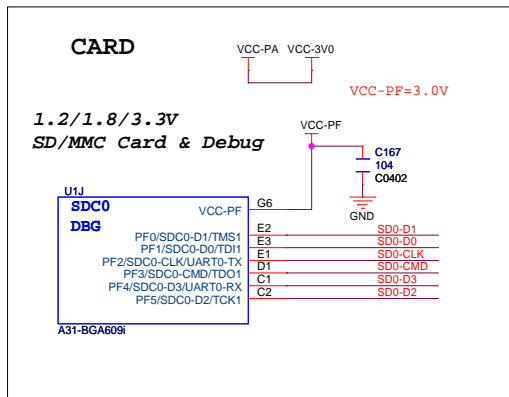

SD卡与TF卡为二选一贴片

SD0-DE<< SD0-DET

D

C

B

A

D

C

B

A

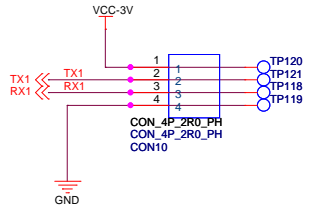
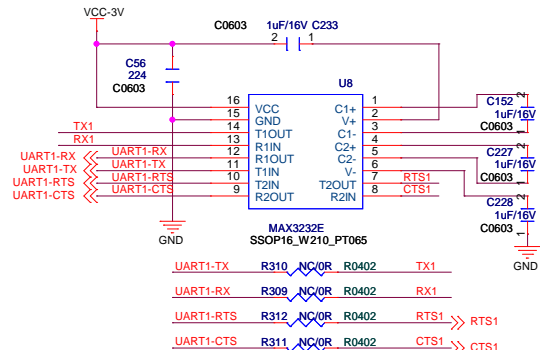
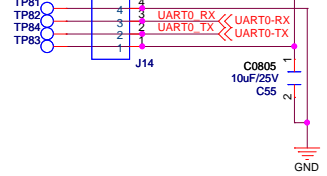

UART4为RS485串口

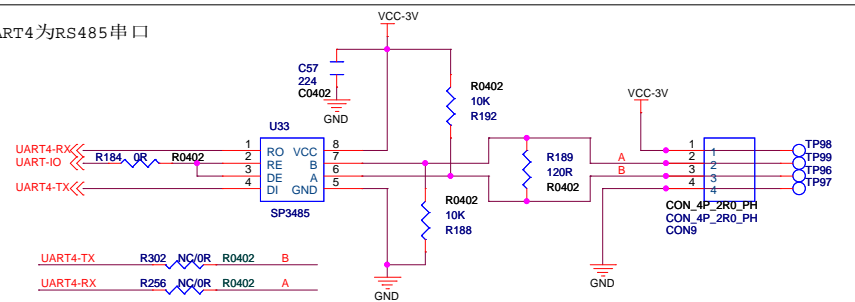

R255 R256使用的时候可以将U33电路去掉不用
此时CON9变为TTL串口方式通讯

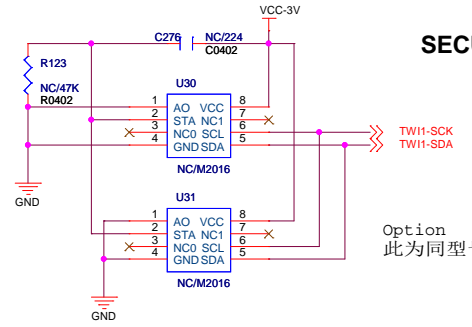
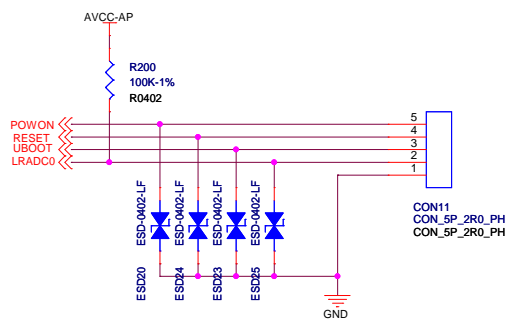

SECURITY IC M2016

Option
此为同型号不同封装，二选一贴片

GMAC

10/100/1000 RGMII Ethernet PHY

Note 1: The Trace length between La and PHY's Pin48 must be within 0.5 cm. CJ(22uF) and CK(0.1uF) to La must be within 0.5cm.

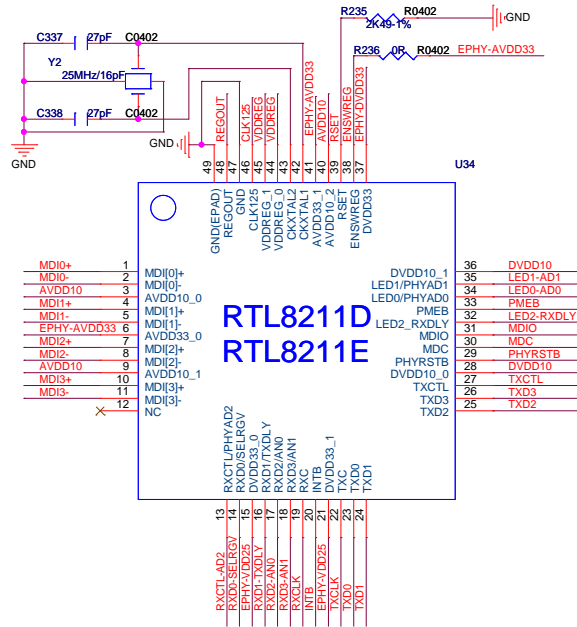

PHYAD0=1: LED0 Low Active
PHYAD1=0: LED1 High Active
RXDLY=1: LED2 Low Active
CD, CE, CF reserve for EMI.

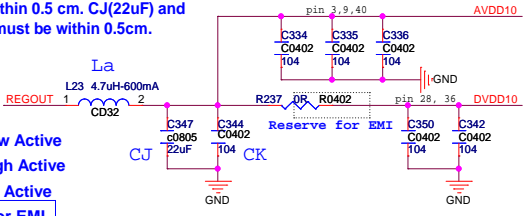

Differential pairs
Z0= 100 ohm

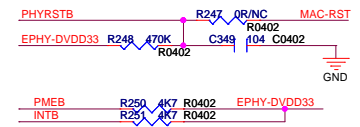

Place filter network close to CLK125.
Reserved for EMI

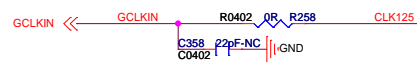

Place filter network close to RX_CLK.
Reserved for EMI

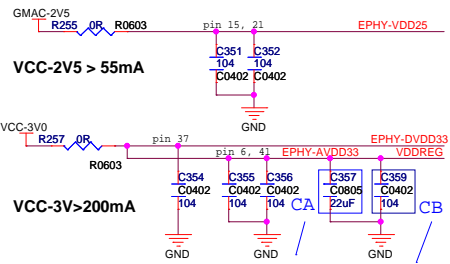
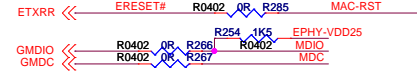
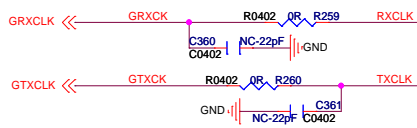

Note 2: The Trace length from CA(22uF),CB(0.1uF) to Pin 44,45(VDDREG) must be within 0.5 cm. The trace width from AVDD33 to Pin 44,45 should >40mils.

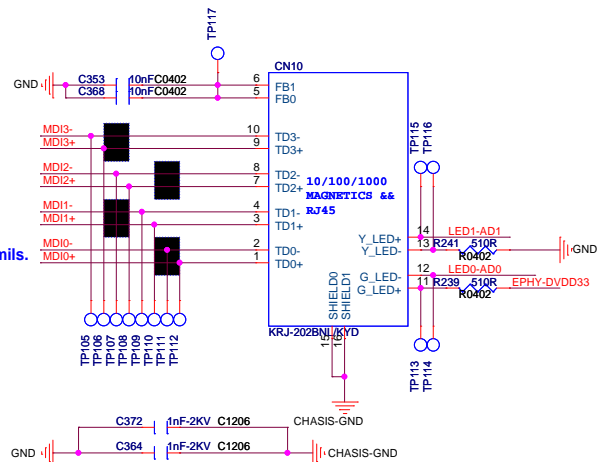
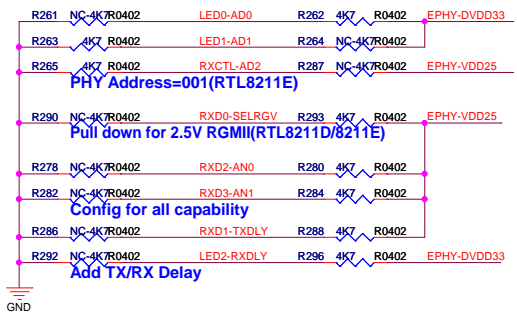

3G MODULE

RF Microstrip
Z0= 50 ohm

U42与MIE1为二选一使用

After AP Power-Down, VBAT-EXT still on,
IOs of BB should be still kept on the right level!!
Take Care of polarity of the Control Signals....

- BB-PCM-DOUT << 3G-PCM-OUT
- BB-PCM-CLK << 3G-PCM-CLK
- BB-PCM-SYNC << 3G-PCM-SYNC
- BB-PCM-DIN << 3G-PCM-IN
- BB-UART-CTS << 3G-UART-CTS
- BB-UART-RXS << 3G-UART-RXS
- BB-UART-RX << 3G-UART-RX
- BB-UART-TX << 3G-UART-TX

- 3G-DMK <<
- 3G-DP <<

- PM0 << MU-WAKEUP-OUT
- PM1 << 3G-PWRON-N
- PM2 << MU-WAKEUP-IN

- PM3 << 3G-RST
- 3G-IO-PWRON << 3G-IO-PWRON

Note:
If the POWER Switch Circuit below do not be used, this TWO Resistor can not be NC!!

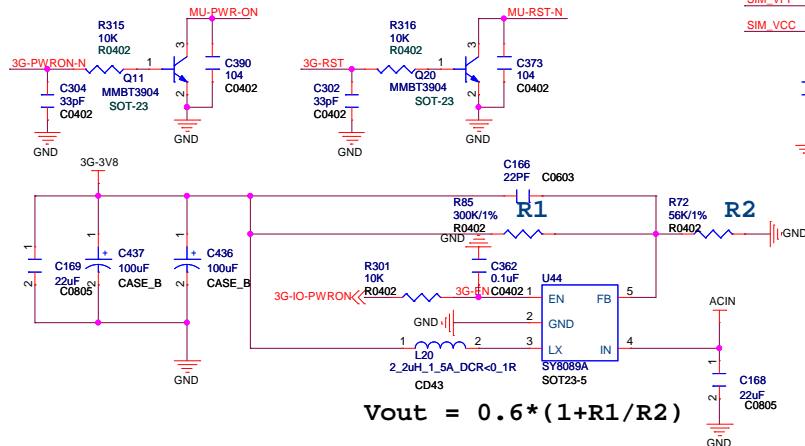
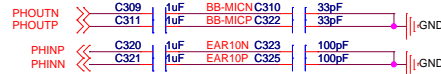
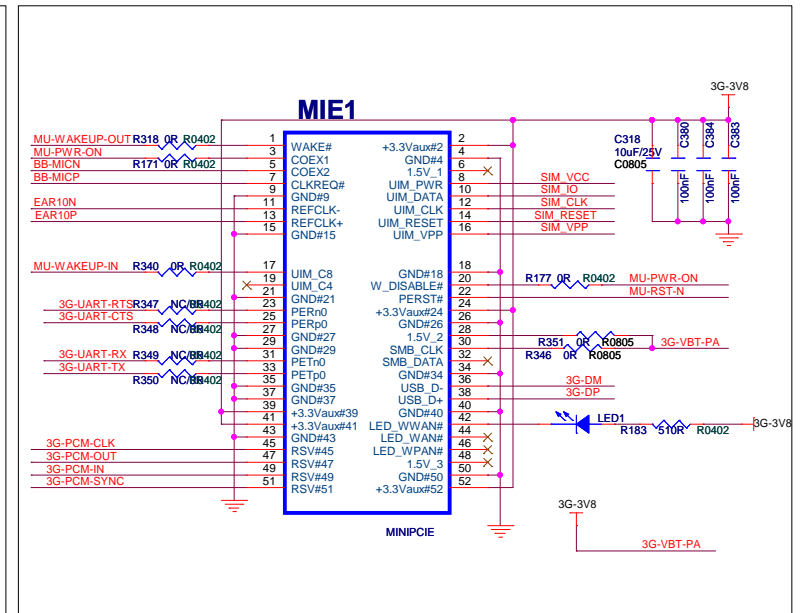
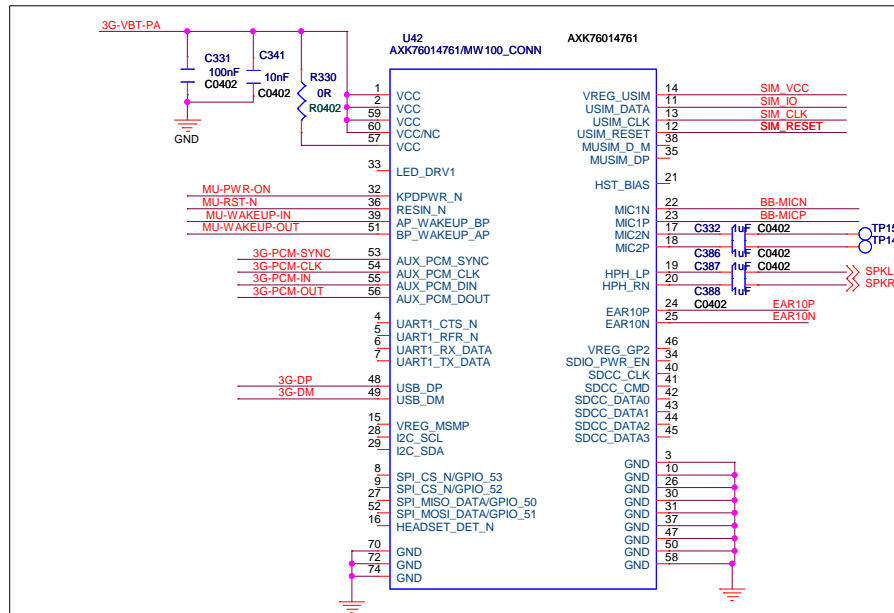

$$V_{out} = 0.6 * (1 + R1/R2)$$

RUIM socket

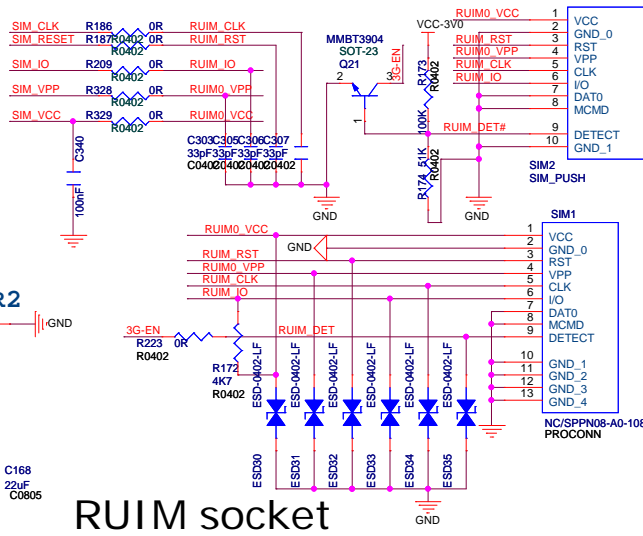

BASEBAND

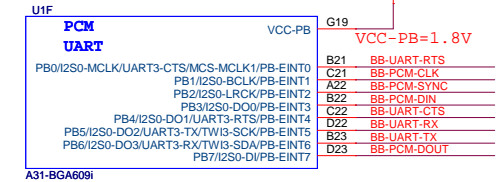

After AP Power-Down, VBAT-EXT still on,
IOs of BB should be still kept on the right level!!
Take Care of polarity of the Control Signals....

Allwinner Technology Co., Ltd		
Design Name		
A31_PAD_STD		
Size	Page Name	Rev
A3	3G	1.0
Date:	Thursday, March 13, 2014	Sheet 14 of 18

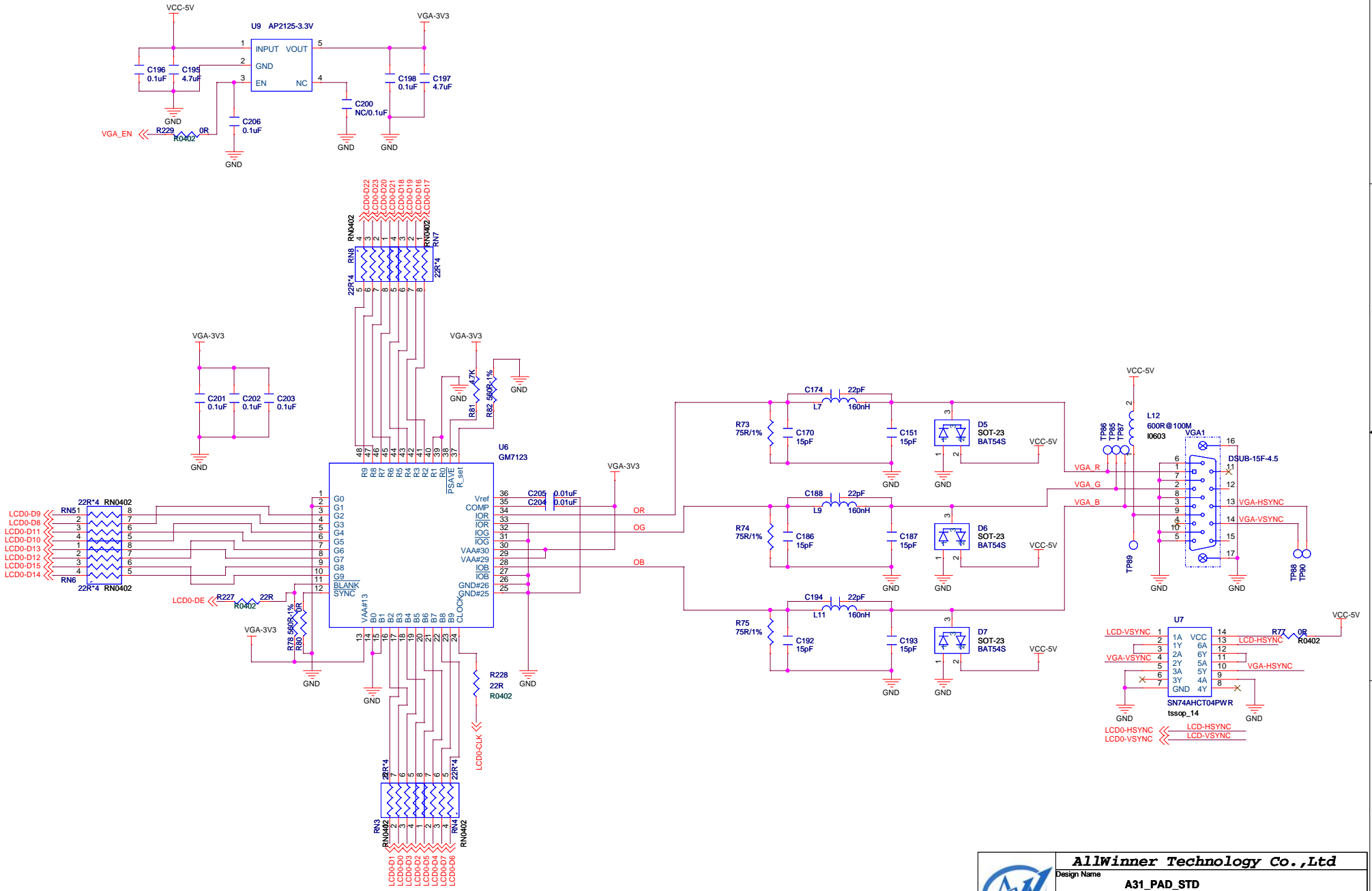

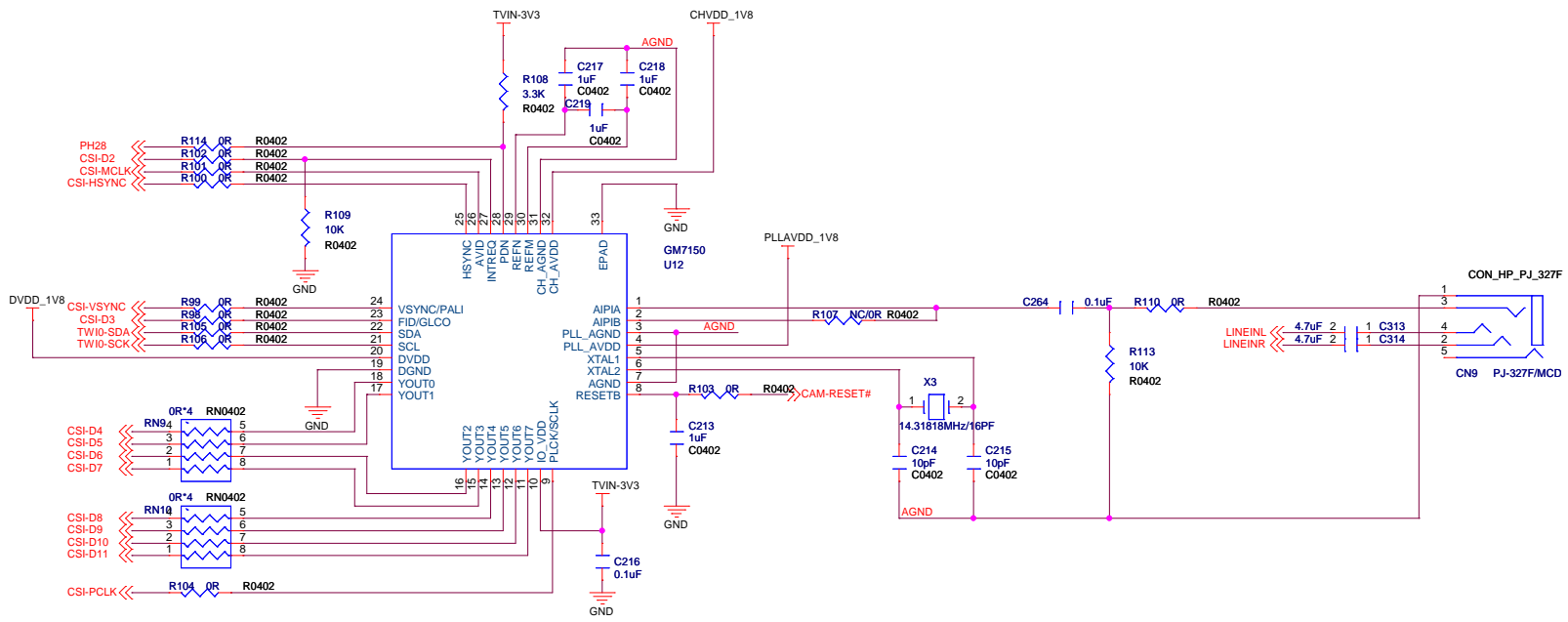
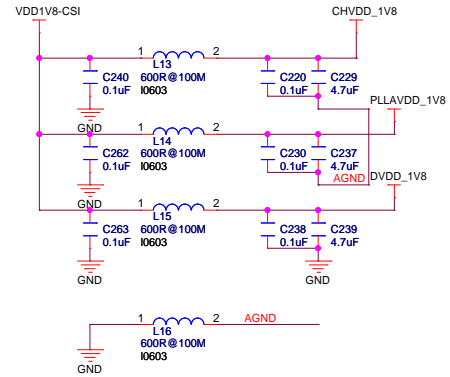
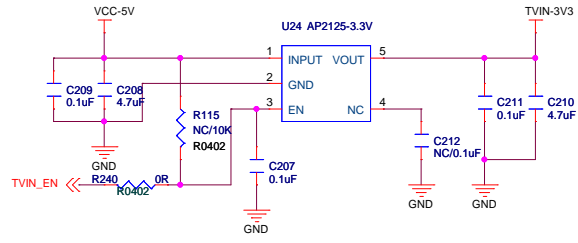

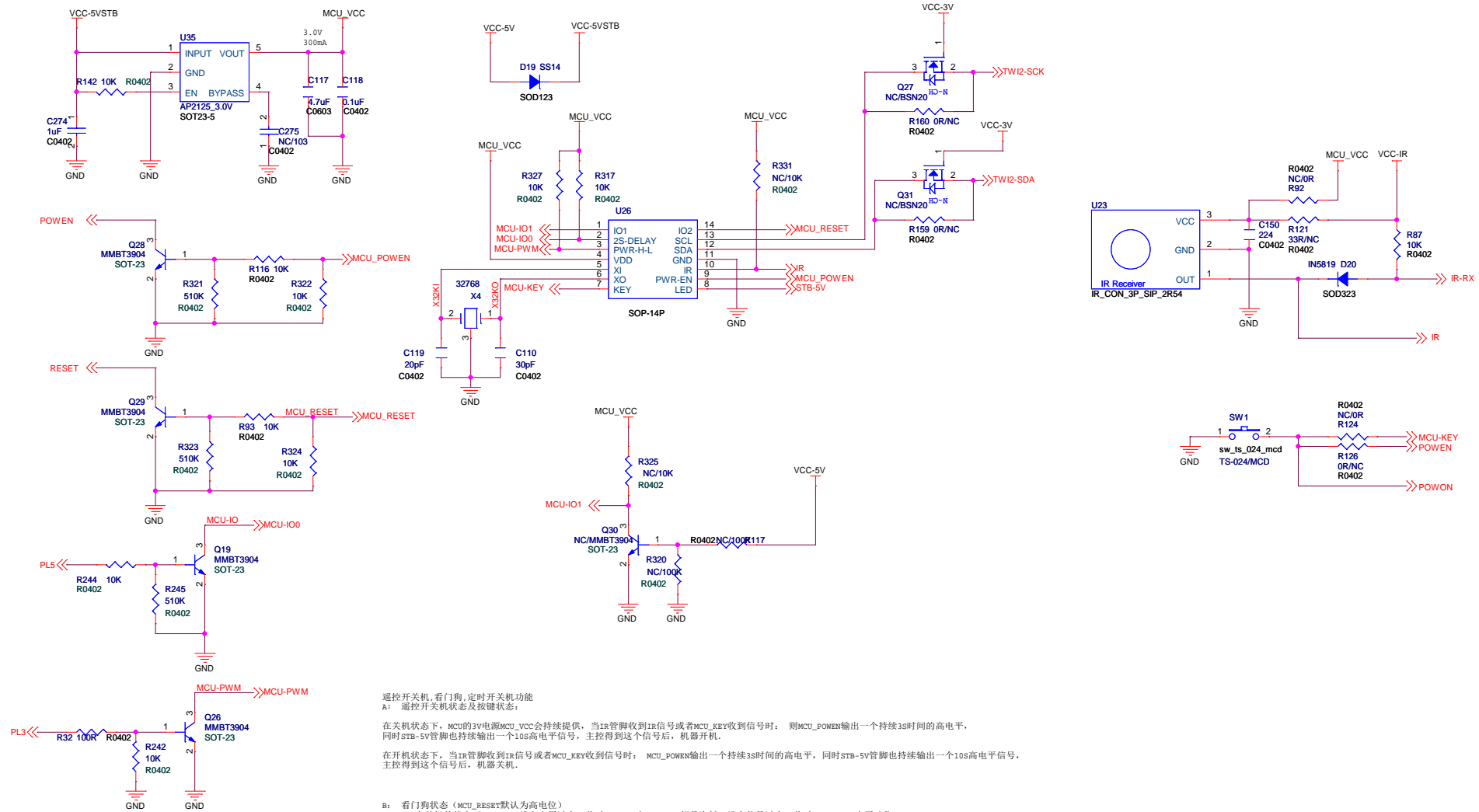

遥控开关机,看门狗,定时开关机功能

A: 遥控开关机状态及按键状态:

在关机状态下, MCU的3V电源MCU_VCC会持续提供, 当IR管脚收到IR信号或者MCU_KEY收到信号时: 则MCU_POWER输出一个持续3S时间的高电平, 同时STB-5V管脚也持续输出一个10S高电平信号, 主控得到这个信号后, 机器开机。

在开机状态下, 当IR管脚收到IR信号或者MCU_KEY收到信号时: MCU_POWER输出一个持续3S时间的高电平, 同时STB-5V管脚也持续输出一个10S高电平信号, 主控得到这个信号后, 机器关机。

B: 看门狗状态 (MCU_RESET默认为高电平)

1: 在关机的状态下, VCC_3V没有电压过来, 此时MCU-IO0与MCU-PWM都是为低, 没有信号过来, 此时MCU_RESET也无动作

2: 在开机的过程中, VCC_3V有电压过来, 此时MCU-IO0这个端口会一直为高, 此时MCU_RESET也无动作

3: 在已经完全开机进入系统后, MCU-IO0这个端口通过主控控制为低, 但此时 MCU-PWM这个管脚会在5秒钟的时间内给一个高脉冲过来, 则MCU_RESET管脚不动作, 如果5秒钟内MCU-PWM都没有信号给过来, 则MCU_RESET输出一个时间为1秒钟的高电平出来达到复位作用

(备注: 时序上设定, MCU-PWM要比MCU-IO0早1S的时间, 5秒内是指第一次信号过来后, 间隔5秒钟的时间, 但第二个信号可能在这个5秒的任何时间过来第二个信号过来后, 5秒钟的时间重新计数)

C: 定时开关机状态:

在开机状态下, CPU通过I2C接口给MCU发定时命令

在关机状态下, 定时时间完成设备开机, MCU_VCC是持续供电的, 首先检测MCU-IO1端口: 如果为高, 则STB-5V管脚持续输出高电平信号, 12V电源开始供电, 设备开机。为低时, 再检测MCU-IO0端口, 如果为低, 则MCU_POWER输出一个3秒的高电平, 设备开机。

在开机状态下, 定时时间完成设备关机, MCU_VCC是持续供电的, 同开机检测流程, MCU-IO1和MCU-IO0都是低电平, 则MCU_POWER输出一个3秒的高电平, 设备关机。等待60秒后, STB-5V管脚的电平翻转为低电平, 12V供电停止。

D: MCU-KEY 按键功能等同与IR功能

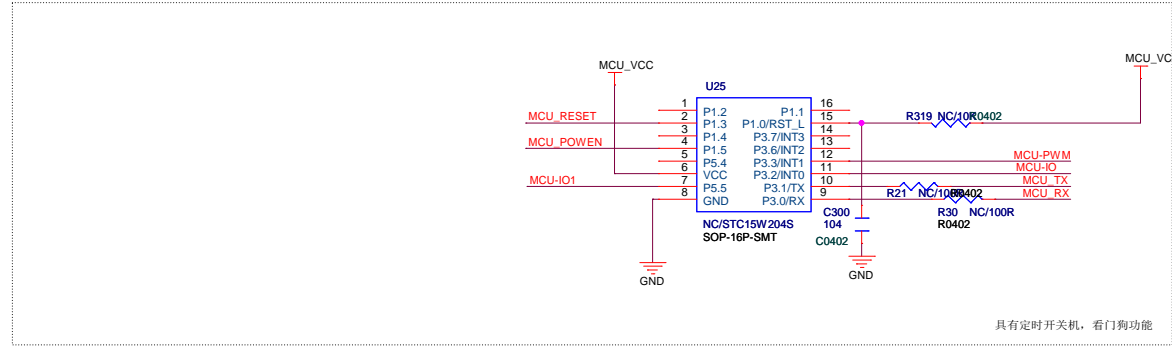
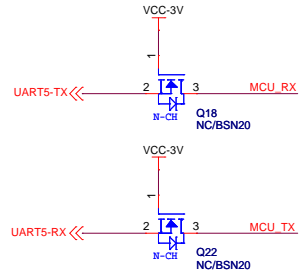

遥控开关机及看门狗功能

A: 遥控开关机状态:

在关机状态下, MCU的3V电源MCU_VCC会持续提供, 但此时MCUIO及MCUPWM都是低, 当IR管脚收到第一次IR信号时, 会检测下MCUIO这个端口。如果为低, 则POWER管脚输出一个持续3秒钟的高电平信号, 达到开机目的。当IR管脚收到第二次IR信号时, 也要检测下MCUIO这个端口, 只有在MCUIO为低的状态下, MCU_POWER管脚才再次输出一个持续3秒钟的高电平信号, 达到开机的目的, 重复循环这两个状态。

注意问题点: MCUIO这个管脚必须在机器开启完全进入到系统后, 主控再经DOG_EN给出一个高位, 打开Q19使其为低。此处这样设定是为了避免用户在连续按遥控时, 而使MCU持续间断的输出高低位, 从而扰乱机器的开关机状态。

B: 看门狗状态 (MCU_RESET默认为高电位)

1: 在关机的状态下, VCC_3V没有电压过来, 此时MCUIO与MCUPWM都是为低, 没有信号过来, 此时MCU_RESET也无动作。

2: 在开机的过程中, VCC_3V有电压过来, 此时MCUIO这个端口会一直为高, 此时MCU_RESET也无动作。

3: 在已经完全开机进入系统后, MCUIO这个端口通过主控控制为低, 但此时MCUPWM这个管脚会在5秒钟的时间内给一个高脉冲过来, 则MCU_RESET管脚不动作。

如果5秒钟内MCUPWM都没有信号给过来, 则MCU_RESET输出一个时间为1秒钟的低电平出来达到复位作用。

(备注: 时序上设定, MCUPWM要比MCUIO早1s的时间, 5秒内是指第一次信号过来后, 间隔5秒钟的时间, 但第二个信号可能在这个5秒的任何时间过来。

第二个信号过来后, 5秒钟的时间重新计数)